

*Landini*<sup>®</sup>

FRONT-END LOADERS  
**TurboLift**



A blue Landini tractor is shown in a field, equipped with a front loader bucket filled with hay. The tractor is positioned on the left side of the frame, facing right. The background features a clear blue sky with some light clouds and a line of trees in the distance. The foreground is a field of golden-brown grass. A teal-colored banner is overlaid on the right side of the image, containing the text "Landini tractor and 'TurboLift'".

**Landini tractor and "TurboLift"**



## front loader: a winning pair

o keep pace with the demands of an increasingly dynamic global market, *Landini* has strategically decided to produce a comprehensive range of front-end loaders complete with attachments.

The expertise acquired over more than a century of activity has enabled *Landini* to develop a range of loaders named **"TurboLift"** designed to suit the *MISTRAL*, *REX*, *ALPINE*, *POWERFARM*, *VISION*, *MYTHOS* and *LANDPOWER* tractor series.

The new front loaders will be mainly used in agriculture for loading, transporting and handling farming products, but will also cater for a variety of industrial applications, thanks to the wide range of attachments available (buckets, forks, etc.)

The **"TurboLift"** front loaders feature a heavy-duty construction and offer unequalled versatility.

The unique quick-attach/detach system allows fast mounting and dismounting of the loader from the tractor. The loader mounting position with respect to the tractor's centre of gravity and the monocoque construction of the arms, designed to make the loader frame ultra lightweight and rugged, increase the loading capacity of the front axle while improving the tractor stability and safety.

These features make the **"TurboLift"** a modern instrument that will maximise the productivity of *Landini* tractors.



## HIGH EFFICIENCY OF "TURBOLIFT" FRONT LOADERS



The **"TurboLift"** front loader has been designed to fully integrate with the features and dimensions of the *Landini* tractors. The range of **"TurboLift"** loaders designed to suit the various *Landini* tractors comprises the following models:

The **No Levelling ECO** (10 – 15 - 20 – 30 – 40 series) and **No Levelling TOP** (10 – 15 - 20 – 30 – 40 series ) versions come without self-levelling system for 45 to 150 HP tractors (*fig. A*).

The **Techno Levelling COMPACT** (830 series) , **Techno Levelling ECO** (10 – 15 - 20 – 30 – 40 series) and **Techno Levelling TOP** (10 – 15 - 20 – 30 – 40 – 50 series) versions are equipped with mechanical self-levelling system for 30 to 200 HP tractors. (*fig. B*).

The **Hydro Levelling ECO** ( 20 – 30 – 40 series ) and **Hydro Levelling TOP** (20 – 30 – 40 – 50 series ) versions feature a hydraulic self-levelling system for 60 to 200 HP tractors (*fig. C*).

The **Eco** and **Top** models differ from each other for the loader design and for the lifting cylinders which allow different load capacities (see the Technical Features table).

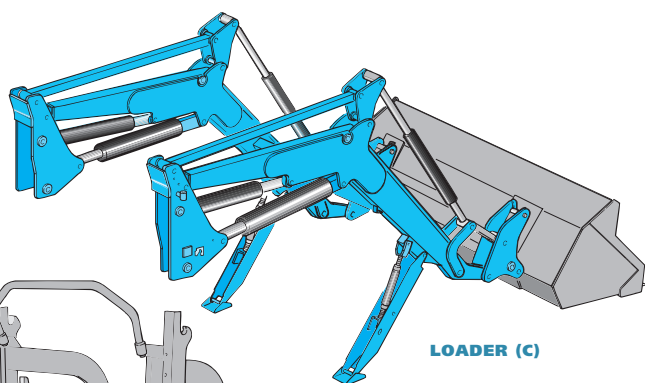

LOADER (C)

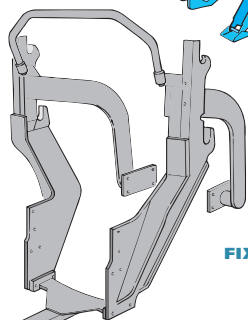

FIXED CHASSIS (T)

The loader frame, that differs from one model to the other, is fixed to the tractor chassis from the forecarriage to the rear final drives.

The unique quick-attach/detach system makes the tractor/loader combination extremely efficient. This system is a sort of hinge area which absorbs the loads generated at the radiator support, thus relieving the stress on the front axle.

Furthermore, thanks to the unique design of the **"TurboLift"**, the point where the loader hinges onto the frame is located much closer to the tractor's centre of gravity than in competitive front-end loaders, while the monocoque construction of the arms makes the loader frame lighter and stronger. Both features result in increased front axle load capacity and enhanced tractor stability and safety.

When fitted with fork, the **"TurboLift"** loader turns out particularly efficient for handling large bales. In this case, the special design of the loader allows the fork to reach a maximum height of four meters stacking up to five bales, while ensuring a clearance of approximately 40 cm between the pile of bales and the tractor hood (*fig. D*).

These design features ensure excellent manoeuvrability and all-round visibility in any condition. Visibility is further improved by the clear sliding sunroof mounted as standard on *Landini* tractor cabs (*fig. E*).

For improved manoeuvrability the loader is equipped with a level indicator which informs the operator of the position of the attachment over the ground.

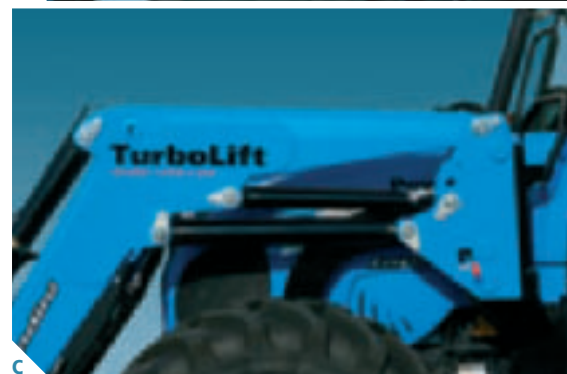



## JOYSTICK MONOLEVER: CONTROL FOR SIMPLE USE



The loader is controlled via a monolever *joystick* located in comfortable and ergonomic position on the driver's right. (fig. A).

The *joystick* lever gives the driver total control of the six main functions for operation of the loader and attachments:

- › *Joystick pos. 1*: Loader lowering;
- › *Joystick pos. 2*: Loader raising;
- › *Joystick pos. 3*: Bucket rollback;
- › *Joystick pos. 4*: Bucket dumping.

By pressing the electrohydraulic control (*pushbutton P*) integrated into the *joystick* lever, the following hydraulic attachments, connected to the electrovalve located on the front of the loader, can be operated:

- › grab for large wrapped round bales;
- › hydraulic fork for large wrapped round bales;
- › hydraulic manure fork with grapple.

The pushbutton *P*, therefore, allows switching from the bucket rollback and dumping positions 3 and 4 to the additional hydraulic functions (positions 3P and 4P) for activating the hydraulically-operated attachments.

The *joystick* is also equipped with a sliding ring which locks and releases the lever for increased safety.

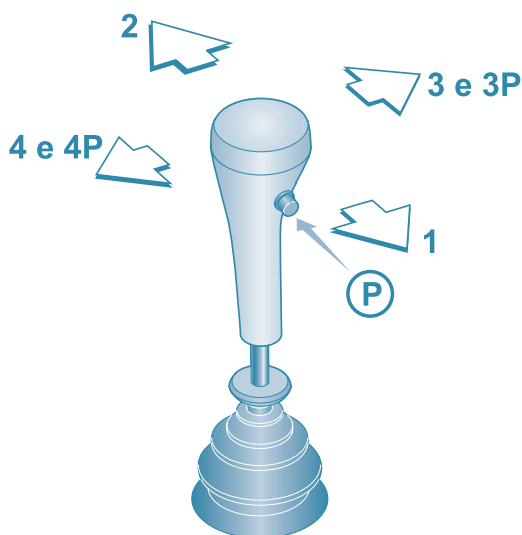



## VERSATILE HYDRAULICS



The hydraulic system of the front-end loader features two dedicated auxiliary valves controlled by the *joystick* lever.

The electrohydraulic control (pushbutton P) integrated into the joystick lever (*fig. A page 4*) controls an electrovalve located on the front of the loader. The electrovalve is equipped with hydraulic intakes which supply the cylinders of the attachments that are provided with additional hydraulic functions (*fig. C*).

When the loader is removed from the tractor, the rear quick-couplers can be used for other jobs and operated with the same *joystick* lever thus increasing the tractor versatility.

The hydraulic lines which enable the tractor to operate the loader cylinders are connected by way of a Flash quick-release multi-coupling system to be used for dismantling the loader from the tractor (*fig. D*).

The hydraulic lift cylinders can be optionally integrated with two nitrogen-filled shock absorbers designed to minimise recoils for improved driving performance on uneven ground (*fig. C*).





## QUICK-ATTACH/DETACH SYSTEM FOR EASY MOUNTING



The loader is fully integrated into the tractor frame thanks to a unique patented quick-attach and detach system which makes for fast mounting and dismounting of the loader and attachment. In a matter of minutes the system enables the loader to be removed from the tractor and parked.

To remove the attachment from the tractor, lower the loader with the attachment to the ground and extract the parking stands by unscrewing the relevant pins (*fig. A*). Release the locking device by turning the lever L located on either side of the loader (*fig. B*). Disengage the *Flash* multi-coupler to disconnect simultaneously all hydraulic lines from the tractor (*see fig. D page 5*). Finally back the tractor slowly. Now the tractor is ready for further use (*fig. C*).

The loader mounting operations are equally simple and fast.





## AND DISMOUNTING

### Coupling and uncoupling of attachment.

The uncoupling of the attachment from the loader is easy to perform; just lower the attachment to the ground and stop the tractor engine. Disengage the pins which secure the attachment to the loader (*fig. D*) by turning the lever in anti-clockwise direction. Restart the engine, lower the loader until it disengages from the fixed U-shaped hooks located on the attachment and back the tractor (*fig. F*).

All attachments feature a **"EURO HITCH"** coupling hook that is designed to be compatible also with attachments not supplied by *Ladini* (*fig. E*).

Coupling of the attachment is equally simple and fast.

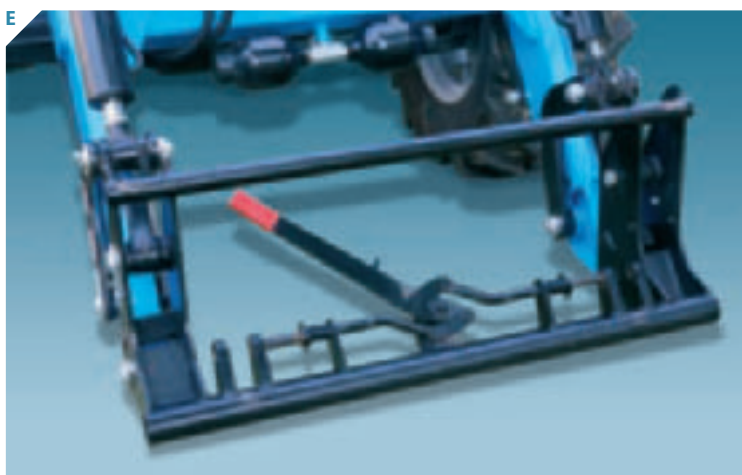

# TECHNICAL FEATURES OF "TURBOLIFT" FRONT LOADERS

- Loader without self-levelling system (**NO LEVELLING**).
- Loader with mechanical self-levelling system (**TECHNO LEVELLING**).
- Loader with hydraulic self-levelling system (**HYDRO LEVELLING**).
- Frame from forecarriage to rear axle shafts.
- Hydraulics specially designed to suit the tractor features.
- Two pairs of double-acting hydraulic cylinders to control respectively raising/lowering of loader and operation of attachment.
- Adjustable support feet.
- Innovative quick-attach/detach system for easy mounting/dismounting of loader from tractor.
- EURO HITCH** coupling hook for quick coupling/uncoupling of attachment.
- Level indicator indicating the position of the attachment over the ground.
- Flash** quick-coupling system for loader/tractor hydraulics.
- Third hydraulic line to activate the attachment hydraulic functions.
- Control via **joystick monolever**.
- Shock absorbers** for lifting cylinders.

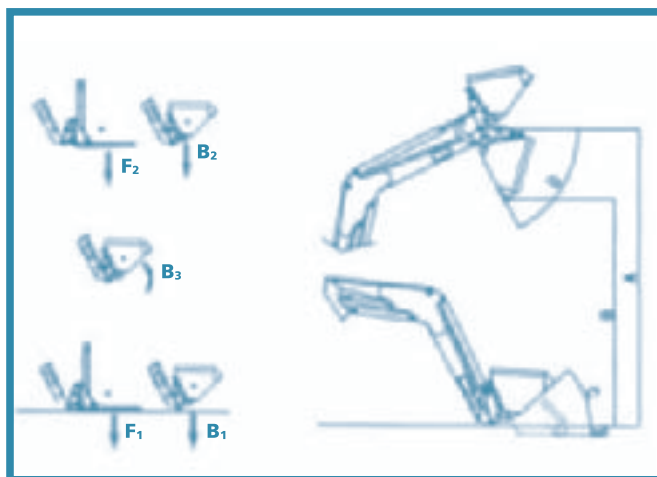

LIFTING CAPACITY DIAGRAM



Technical features	Model	ECO No Levelling						TOP No Levelling						
		Rex Powerfarm 60 10	Alpine 15	Powerfarm 20	Vision 20	Mythos 105 30	Mythos 115 40	Rex Powerfarm 60 10	Alpine 15	Powerfarm 20	Vision 20	Mythos 105 30	Mythos 115 40	
Series	Engine power	CV	45-85	45-85	60-100	60-100	70-120	100-150	45-85	45-85	60-100	60-100	70-120	100-150
<b>Lift capacity at 180 bar</b>														
	* with bucket on ground	B1 Kg	900	900	1300	1300	1500	1700	1200	1200	1450	1450	1600	2200
	* with bucket at max. height	B2 Kg	800	800	1170	1170	1350	1530	1050	1050	1360	1360	1530	1950
	* with fork on ground	F1 Kg	900	900	1300	1300	1500	1700	1200	1200	1450	1450	1600	2200
	* with fork at max. height	F2 Kg	800	800	1170	1170	1350	1530	1050	1050	1360	1360	1530	1950
	breakaway capacity front of bucket	B3 Kg	1500	1500	1500	1500	1500	1500	1400	1400	2000	2000	2000	2000
<b>Max lift height</b>														
	at bucket pivot	A mm	3200	3300	3800	3800	3870	4100	3200	3300	3800	3800	3870	4100
	with bucket dumped	B mm	2260	2360	2940	2940	3010	3200	2260	2360	2940	2940	3010	3200
<b>Operating time</b>														
	raising time to full height		7"	7"	7"	7"	7"	9"	9"	9"	9"	9"	9"	9"
	bucket dumping		5"	5"	5"	5"	5"	5"	5"	5"	5"	5"	5"	5"
<b>Working angles</b>														
	bucket rollback on ground	C	45°	45°	45°	45°	45°	45°	45°	45°	45°	45°	45°	45°
	bucket dumping on ground	D	90°	90°	90°	90°	90°	90°	55°	55°	55°	55°	55°	55°
<b>Digging depth</b>														
		E mm	150	150	150	150	150	150	150	150	150	150	150	150
<b>Weights</b>														
	without attachment and tractor couplers	mm	370	380	440	440	473	500	450	452	560	560	620	650

\* The lift capacity includes the weight of the attachment (bucket, fork)

Technical features			ECO Techno Levelling					TOP Techno Levelling							
Model			Rex Power farm 60	Alpine 15	Power farm 20	Vision 20	Mythos 105 30	Mythos 115 40	Rex Power farm 60 10	Alpine 15	Power farm 20	Vision 20	Mythos 105 30	Mythos 115 40	Land power 50
Series	CV		45-85	45-85	60-100	60-100	70-120	100-150	45-85	45-85	60-100	60-100	70-120	100-150	115-200
<b>Lift capacity at 180 bar</b>															
* with bucket on ground	B1	Kg	1000	1000	1400	1400	1600	1800	1300	1300	1700	1700	1900	2600	2600
* with bucket at max. height	B2	Kg	900	900	1300	1300	1500	1700	1200	1200	1600	1600	1800	2300	2300
* with fork on ground	F1	Kg	1000	1000	1400	1400	1600	1800	1300	1300	1700	1700	1900	2600	2600
* with fork at max. height	F2	Kg	900	900	1300	1300	1500	1700	1200	1200	1600	1600	1800	2300	2300
breakaway capacity front of bucket	B3	Kg	1500	1500	1500	1500	1500	1500	1400	1400	2000	2000	2000	2000	2000
<b>Max lift height</b>															
at bucket pivot	A	mm	3200	3300	3800	3800	3870	4100	3200	3300	3800	3800	3870	4100	4400
with bucket dumped	B	mm	2260	2360	2940	2940	3010	3200	2260	2360	2940	2940	3010	3200	3500
<b>Operating time</b>															
raising time to full height			7"	7"	7"	7"	7"	9"	9"	9"	9"	9"	9"	9"	9"
bucket dumping			5"	5"	5"	5"	5"	5"	5"	5"	5"	5"	5"	5"	5"
<b>Working angles</b>															
bucket rollback on ground	C		45°	45°	45°	45°	45°	45°	45°	45°	45°	45°	45°	45°	45°
bucket dumping on ground	D		90°	90°	90°	90°	90°	90°	90°	90°	90°	90°	90°	90°	90°
<b>Digging depth</b>	E	mm	150	150	150	150	150	150	150	150	150	150	150	150	150
<b>Weights</b>															
without attachment and tractor couplers		mm	433	443	500	500	533	560	500	502	620	620	680	705	735

\* The lift capacity includes the weight of the attachment (bucket, fork)



Technical features			ECO Hydro Levelling				TOP Hydro Levelling				Compact Techno Levelling	
Model			Power farm 20	Vision 20	Mythos 105 30	Mythos 115 40	Power farm 20	Vision 20	Mythos 105 30	Mythos 115 40	Land power 50	Mistral
Series	CV		60-100	60-100	70-120	100-150	60-100	60-100	70-120	100-150	115-200	830
<b>Lift capacity at 180 bar</b>												
* with bucket on ground	B1	Kg	1400	1400	1600	1800	1700	1700	1900	2600	2600	988
* with bucket at max. height	B2	Kg	1300	1300	1500	1700	1600	1600	1800	2300	2300	750
* with fork on ground	F1	Kg	1400	1400	1600	1800	1700	1700	1900	2600	2600	988
* with fork at max. height	F2	Kg	1300	1300	1500	1700	1600	1600	1800	2300	2300	432
breakaway capacity front of bucket	B3	Kg	1500	1500	1500	1500	2000	2000	2000	2000	2000	–
<b>Max lift height</b>												
at bucket pivot	A	mm	3800	3800	3870	4100	3800	3800	3870	4100	4400	2240
with bucket dumped	B	mm	2940	2940	3010	3200	2940	2940	3010	3200	3500	1660
<b>Operating time</b>												
raising time to full height			7"	7"	7"	9"	9"	9"	9"	9"	9"	9"
bucket dumping			5"	5"	5"	5"	3"	3"	3"	3"	3"	6"
<b>Working angles</b>												
bucket rollback on ground	C		45°	45°	45°	45°	45°	45°	45°	45°	45°	36°
bucket dumping on ground	D		55°	55°	55°	55°	55°	55°	55°	55°	55°	82°
<b>Digging depth</b>	E	mm	150	150	150	150	150	150	150	150	150	150
<b>Weights</b>												
without attachment and tractor couplers		mm	500	500	533	560	610	610	670	695	725	190

\* The lift capacity includes the weight of the attachment (bucket, fork)

# ATTACHMENTS FOR EVERY NEED

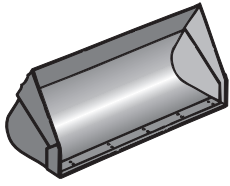

**EARTH BUCKET**

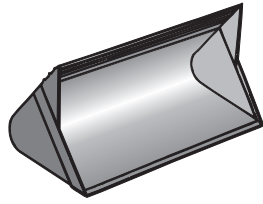

**GRAIN BUCKET**

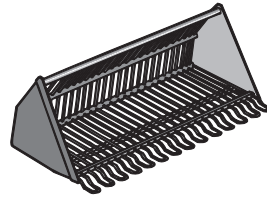

**SUGAR BEET BUCKET**

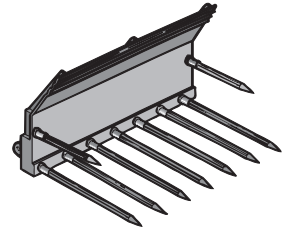

**STONE BUCKET**

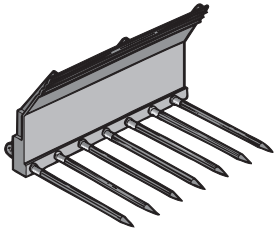

**MANURE FORK**

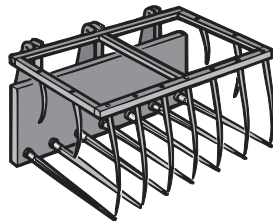

**MANURE FORK WITH GRAPPLE**

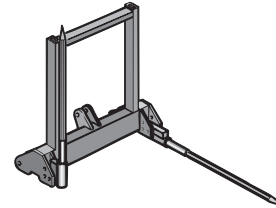

**FORK FOR ROUND BALES**

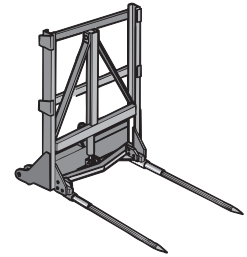

**FORK FOR SQUARE BALES**

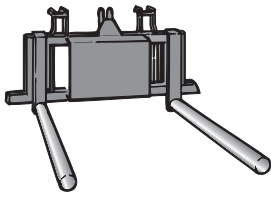

**FORK FOR WRAPPED ROUND BALES**

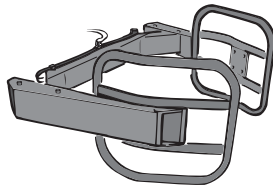

**GRAB FOR WRAPPED ROUND BALES**

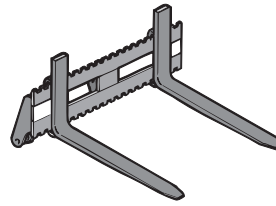

**ADJUSTABLE PALLET FORK TO FEM STANDARDS**

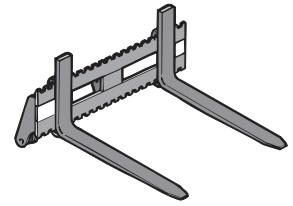

**ADJUSTABLE PALLET FORK WITH SIDE SHIFT TO FEM STANDARDS**

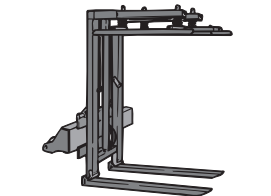

**ADJUSTABLE PALLET FORK WITH SIDE SHIFT AND GRIPPING**

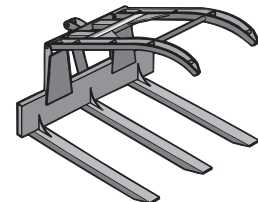

**LOG FORK WITH HYDRAULIC GRIPPING**

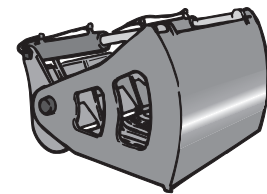

**SILAGE FORK**

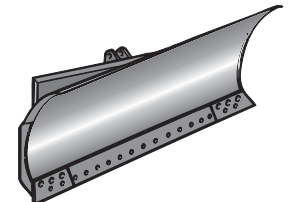

**MECHANICAL ANGLE BLADE**

Artwork: [grupposaldatori@grupposaldatori.com](mailto:grupposaldatori@grupposaldatori.com) - cod. 3680752M1 10/2006  
 the information and pictures in this brochure are purely indicative and may be changed without prior notice.



**Argo Tractors** 42042 Fabbrico [RE] Italia  
 via G. Matteotti, 7  
 t. +39.0522.656.111  
 f. +39.0522.656.476  
[webmaster@argotracors.com](mailto:webmaster@argotracors.com)  
[www.argospa.com](http://www.argospa.com)

  
**ARGO**  
 Gruppo Industriale ARGO

Landini chooses lubricants  
